

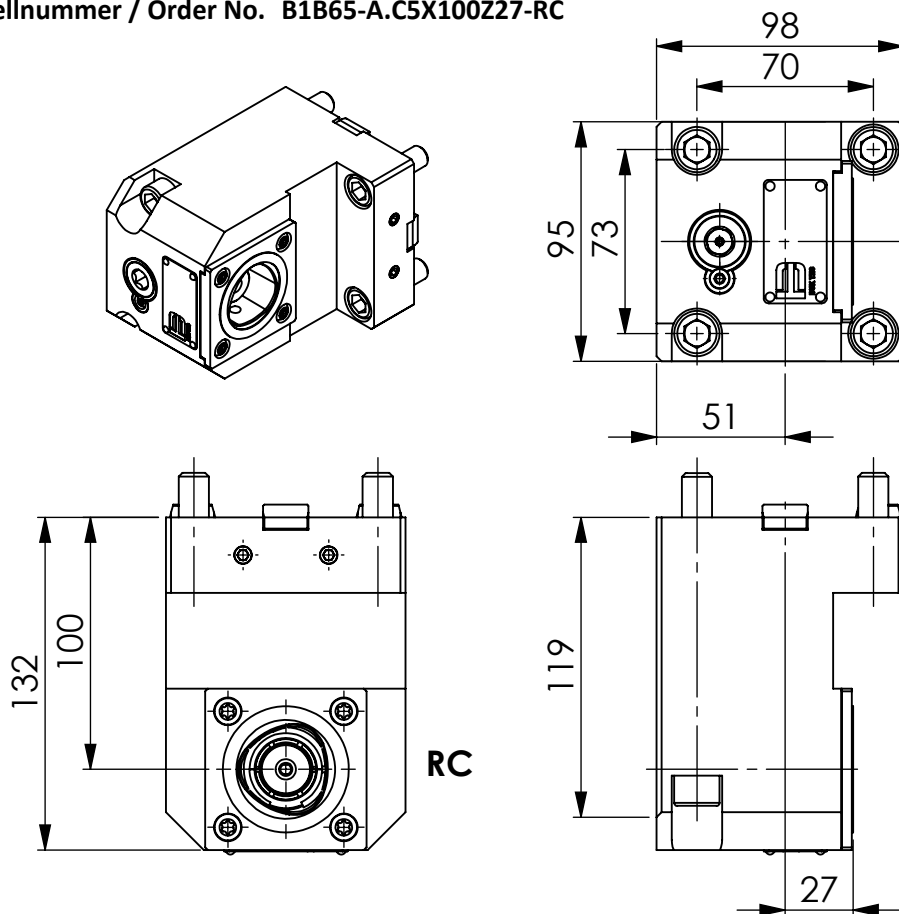

SPANNEINHEIT PSC50, ABGEWINKELT

CLAMPING UNIT PSC50, RADIAL

Bestellnummer / Order No. B1B65-A.C5X100Z27-RC



Technische Daten

Technical specifications

Schaft Shank	Spannbereich clamping range	Kühlungsart Coolant Type	Druck Pressure	Richtung Direction	Gewicht weight
Ø mm	Ø mm	Emulsion	p max bar		kg
65 BMT	Polygon PSC50 - RC	int.	80	universal	7.14

Erforderliches Zubehör nicht im Lieferumfang enthalten
necessary equipment not included

Spannzangensatz collet set test	Spannschlüssel Clamping wrench	Hakenschlüssel Hook wrench
-	-	-